

● Motor Dimensions:

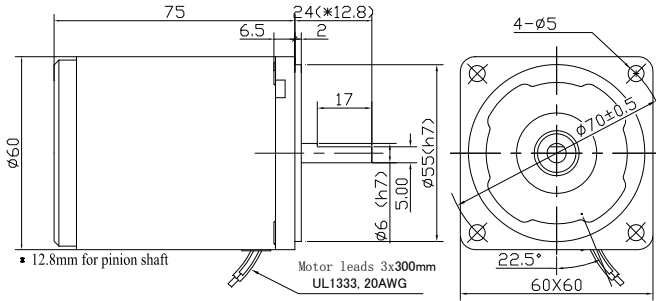

Induction Motors 6W
Frame Size: □60mm (□2.36 in.)



● Induction motor specifications-continuous Rating (leads wire type)



Model		Output Power	Voltage	Freq.	Current	Starting Torque	Rated Torque	Rated Speed	Capacitor
Pinion Shaft	Round Shaft	W	Vac	Hz	Amp	mN.m	mN.m	r/min	μF/V
2IK6GN-A	2IK6A-A	6	1ph110	50	0.24	55	48	1200	3.5/250
				60	0.25	50	40	1450	
2IK6GN-C	2IK6A-C	6	1ph220	50	0.13	50	48	1200	0.8/450
					0.11			1450	
2IK6GN-S	2IK6A-S	6	3ph220	50	0.076	85	48	1200	-
				60	0.065	70	40	1450	

- These motors have built in thermal protectors: If a motor overheats the thermal protector opens and the motor stops. When the motor temperature drops to the rated level, the thermal protector closes and the motor restarts.

● Gearhead dimensions:

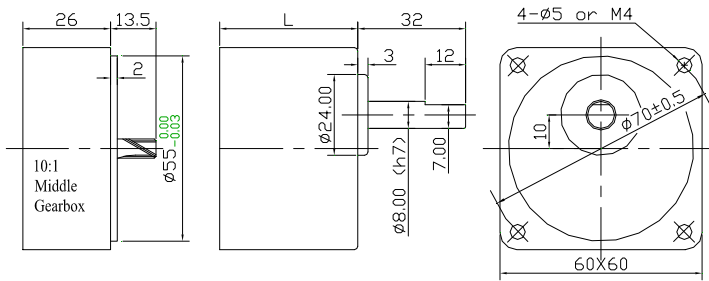

Item	Ratio	L		Weight	
		mm	Kg	lb	
Gearhead (2GNxxK)	3 - 18	32	0.24	0.53	
	25 - 50	42	0.3	0.66	
	60 - 200		0.33	0.73	
Middle gearbox(10:1)			0.2	0.44	
Motor			0.7	1.54	

● Gear Motor-Torque Table

Model	Gear Ratio		X:1	3	3.6	5	6	7.5	9	12.5	15	18	25	30	36	50	60	75	90	100	120	150	180	200		
	Efficiency		%	81										73			66									
	Speed		50Hz	RPM	500	417	300	250	200	166	120	100	83	60	50	41	30	25	20	16	15	12.5	10	8.3	7.5	
2IK6GN-A 2IK6GN-C 2IK6GN-S	2GN□K	50Hz	Nm	0.12	0.14	0.19	0.23	0.29	0.35	0.49	0.58	0.7	0.88	1.1	1.3	1.6	1.9	2.4	2.9	3	3	3	3	3	3	
			Kg.cm	1.22	1.43	1.94	2.35	2.96	3.57	5	5.92	7.14	8.98	11.2	13.3	16.3	19.4	24.5	29.6	30	30	30	30	30	30	
		60Hz	Nm	0.1	0.12	0.16	0.19	0.24	0.29	0.41	0.49	0.58	0.73	0.88	1.1	1.3	1.6	2	2.4	2.6	3	3	3	3	3	3
			Kg.cm	1.02	1.22	1.63	1.94	2.45	2.96	4.18	5	5.92	7.45	8.98	11.2	13.3	16.3	20.4	24.5	2.65	30	30	30	30	30	30

- Enter the gear ratio in the box □. Colored background indicates the output shaft rotate in the same direction as the motor shaft.
- The speed is calculated based on the synchronous speed (50 Hz: 1500rpm; 60Hz: 1800 rpm) by the gear ratio.
- Higher gear ratio (>200) can be achieved by adding a middle gearbox (10:1 only). Using Middle Gearbox limits Max.torque to 3Nm (30kg.cm)

● Connection Diagrams:

● Lead Wire Single Phase

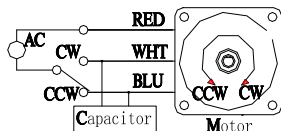

● Lead Wire Three Phase

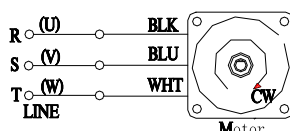

● Capacitor:

Value		Dimensions		
uF	V	L	H	W
2.0 - 2.5	250	37	14	28
0.5 - 1.5	450			
3.5 - 4.0	250	37	18	28
1.8 - 2.5	450			

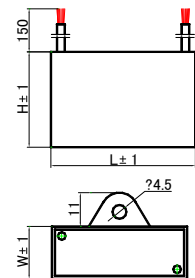

6W Frame Size: □60mm (□2.36 in.)

● **General specifications for AC motors:**

Item	Specifications
Insulation Resistance	100 MΩ or more when 500VDC is applied between the windings and the frame
Dielectric Strength	Sufficient to withstand 1.5 kV at 50/60Hz applied between the windings and the frame for 1 minute
Temperature Rise	Temperature rise of windings should be lower than 80°C. (60°C with fan)
Insulation Class	Class B (130°C)
Overheat Protection	Build in thermal protector (automatic return); Class B (O: 120±5°C, C: 75±15°C)
Ambient Temperature	14°F-104°F (-10°C~+40°C) [three-Phase: 14°F-122°F (-10~+50°C)] (Nonfreezing)
Ambient Humidity	85% or less (Noncondensing)
Degree of Protection	Lead wire type: IP20; Terminal Box Type: IP54

Notes: Above specifications is for motor operated under normal ambient temperature and humidity conditions

● **Permissible load for round shaft motors & Permissible Load Inertia at the Motor Shaft**

Frame Size	Shaft Dia. mm	Permissible overhung load (from end of shaft)				Permissible Load Inertia at the Motor Shaft	
		10 mm		20 mm		J (×10 kg. m ²)	GD (kg. m ²)
		lb	N	lb	N		
□60	6	11.2	50	18	80	0.062	0.25

Permissible thrust load: Avoid thrust load as much as possible or keep it to no more than half the motor weight

● **Permissible load for gearheads**

Frame Size	Gear Ratio	Maximum Permissible torque		Permissible overhung load (from end of shaft)				Permissible thrust load	
		lb-in	N.m	10 mm		20 mm		lb	N
				lb	N	lb	N		
□60mm (□2.3")	3 - 18	26	3	11.2	50	18	80	6.7	30
	25 - 200			27	120	40	180		

● **Heat Radiation Plate Dimension (Material: Aluminum): 115×115 (for 6W motor)**

● **Product Number Codes for Motors:**

2	I	K	6	R	GN	-	C	F
Frame size 2: 60mm 3: 70mm 4: 80mm 5: 90mm 6: 100mm	Motor Type I: Induction R: Reversible T: Torque	Series K: k series	Power 6 = 6W	Control R: speed control motor	Shaft A: round w/ flat A1: round w/keyway GN: Normal Pinion GU: Enhanced Pinion		Voltage & Poles A: Single phase 100~120VAC, 4P B: Single phase 100~120VAC, 2P C: Single phase 220~240VAC, 4P D: Single phase 220~240VAC, 2P S: Three phase 220~240VAC, 4P T: Three phase 220~240VAC, 2P S3: Three phase 380~415VAC, 4P T3: Three phase 380~415VAC, 2P	Accessory F: W/Fan FF: W/forced Fan M: W/Brake T: W/Terminal Box

● **Product Number Codes for Gearheads:**

2	GN	50	K
Frame size 2: 60mm 3: 70mm 4: 80mm 5: 90mm 6: 100mm	Gear Type GN: Normal Gear GU: Enhanced Gear	Gear Ratio 50 = 50:1	Bearing K: Normal Ball Bearing KB: Enhanced for GU Type B: Sleeve bearing

● **Terminal Boxes:**

